

Thank you for purchasing the **Julep Rocker**. This page lists all the contents included in the box. Please take the time to identify the hardware as well as the individual components to this product. As you unpack and prepare for assembly, place the contents on a carpeted or padded area to protect them from damage.

hardware

Missing hardware? Please call **800.606.6387** for replacements.

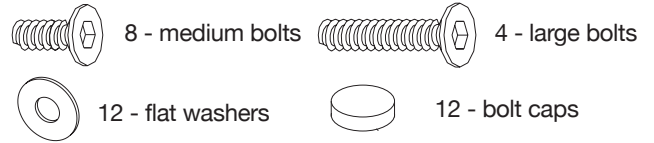

tool required

allen wrench (included)



components

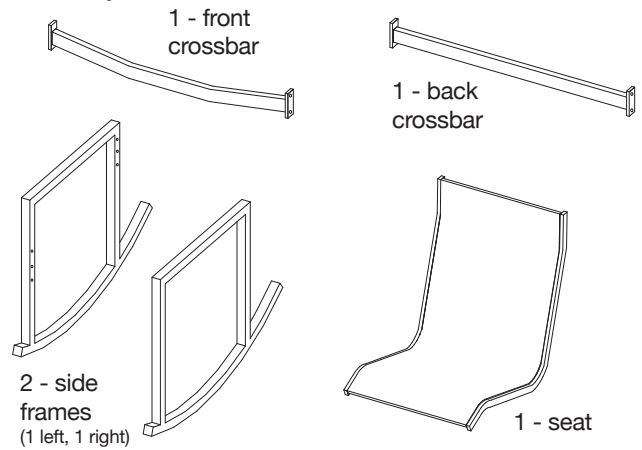

assembly

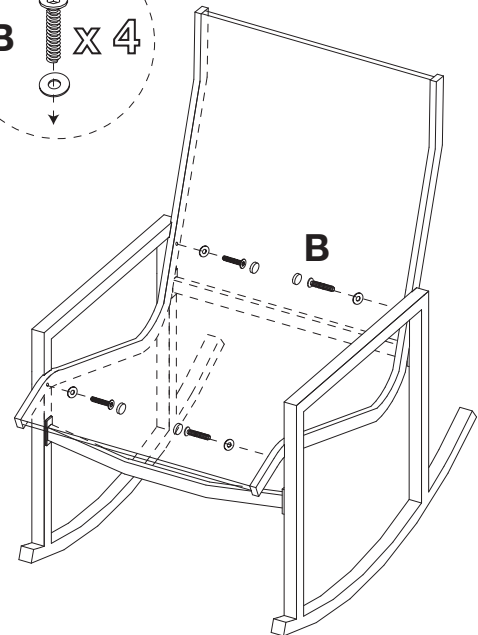
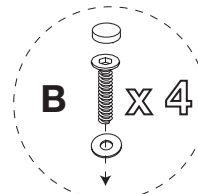
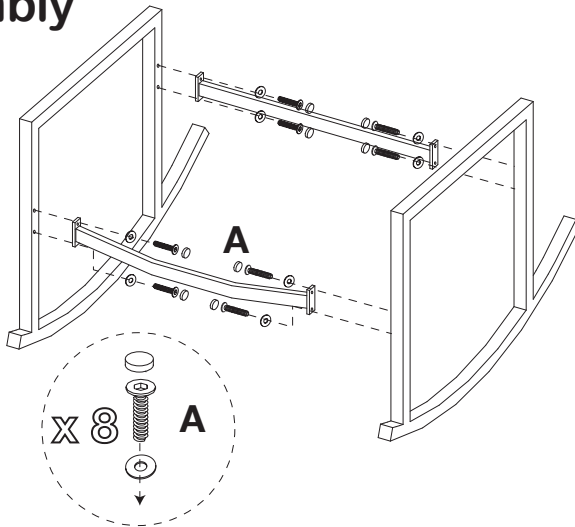

- A. Loosely attach **side frames** to **front and back crossbar** with 4 **medium bolts** and 4 **flat washers** per side as shown.
- B. Loosely attach seat to frame assembly with 4 **large bolts** and 4 **flat washers** as shown. At this point secure, but do not over tighten, all bolts with an **allen wrench**. Cover each bolt with a **bolt cap**. Assembly is now complete.

CLEANING AND CARE

Clean surfaces with a dry or damp soft cloth. Do not use abrasive cleaners.