

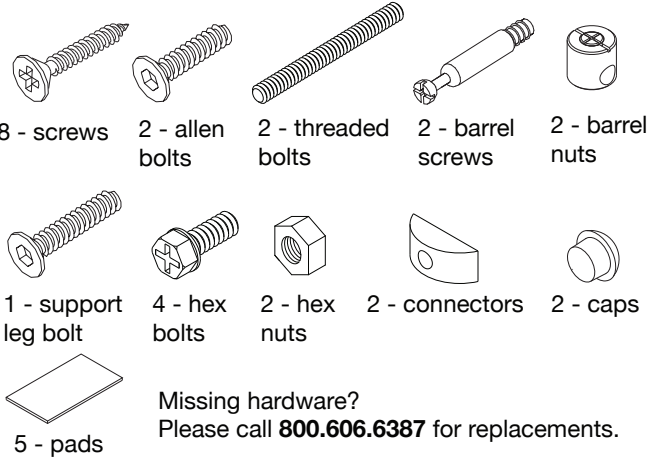

Thank you for purchasing the **Finn Lounger**. This page lists all the contents included in the box. Please take the time to identify the hardware as well as the individual components to this product. As you unpack and prepare for assembly, place the contents on a carpeted or padded area to protect them from damage.

Note: 2 people are required to safely assemble this product.

## hardware



8 - screws    2 - allen bolts    2 - threaded bolts    2 - barrel screws    2 - barrel nuts

1 - support leg bolt    4 - hex bolts    2 - hex nuts    2 - connectors    2 - caps

5 - pads

Missing hardware?  
Please call **800.606.6387** for replacements.

## tools required

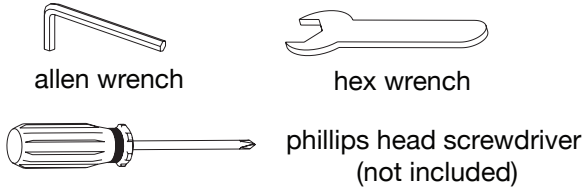

allen wrench    hex wrench

phillips head screwdriver (not included)

( We recommend the use of hand tools instead of power tools )

## components

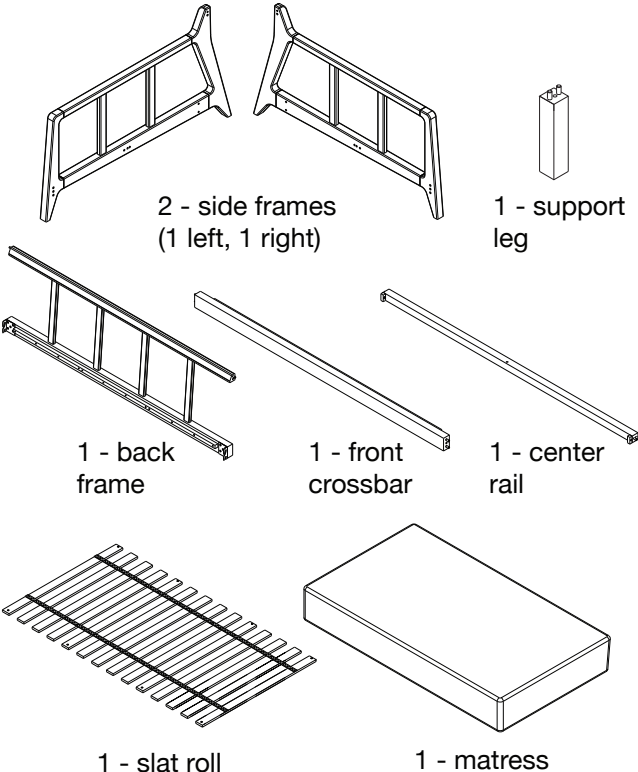

2 - side frames (1 left, 1 right)    1 - support leg

1 - back frame    1 - front crossbar    1 - center rail

1 - slat roll    1 - mattress

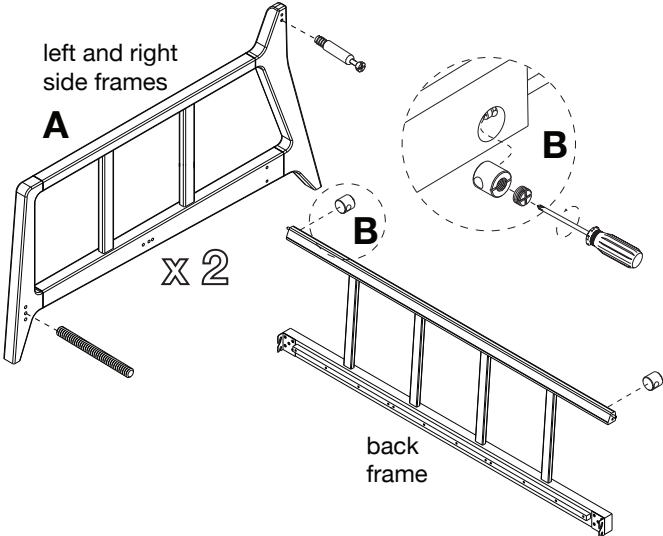

left and right side frames

**A**

**B**

back frame

**1**

A. Insert 1 **barrel screw** and 1 **threaded bolt** into **left and right side frames** as shown. Secure, but do not over tighten, the barrel screws with a **phillips head screwdriver**.

B. Using a screwdriver, remove **set screws** from each **barrel nut** and set aside. Insert **barrel nuts** into the **back frame** as shown. Align the hole on the side of each **barrel nut** with the hole on the end of the **back frame**.

**2**

NOTE: Do not fully tighten the bolt

left side frame

front crossbar

Insert **connector** into **front crossbar** as shown. Fit **bolt** of **side frame** into **front crossbar**. Loosely attach with 1 **hex nut** using a **hex wrench** as shown.

**3**

NOTE: Do not over tighten the screw

left side frame

center rail

support leg

A. Loosely attach **center rail** to **left side frame** with 1 **allen bolt** using an **allen wrench**.  
 B. Fit dowels of **support leg** into corresponding hole of **center rail** and secure with 1 **support leg bolt** using a screwdriver.

**4**

With the assistance of another adult, fit **barrel screw** of **left side frame** into corresponding hole of **back frame**. Secure **barrel screw** by inserting a **set screw** into the **barrel nut**. Loosely secure set screw, using a screwdriver. Make sure set screw securely engages the barrel screw.

B. Attach 1 **cap** as shown.

C. Loosely attach bracket of **back frame** to **left side frame** with 2 **hex bolts** as shown using a screwdriver. Do not over tighten the bolts.

left side frame

back frame

A. Repeat steps 2-4 for **right side frame**. At this point, fully tighten all bolts and screws.  
 B. Adhere 1 **pad** onto each foot of assembled unit as shown. Press firmly to secure.

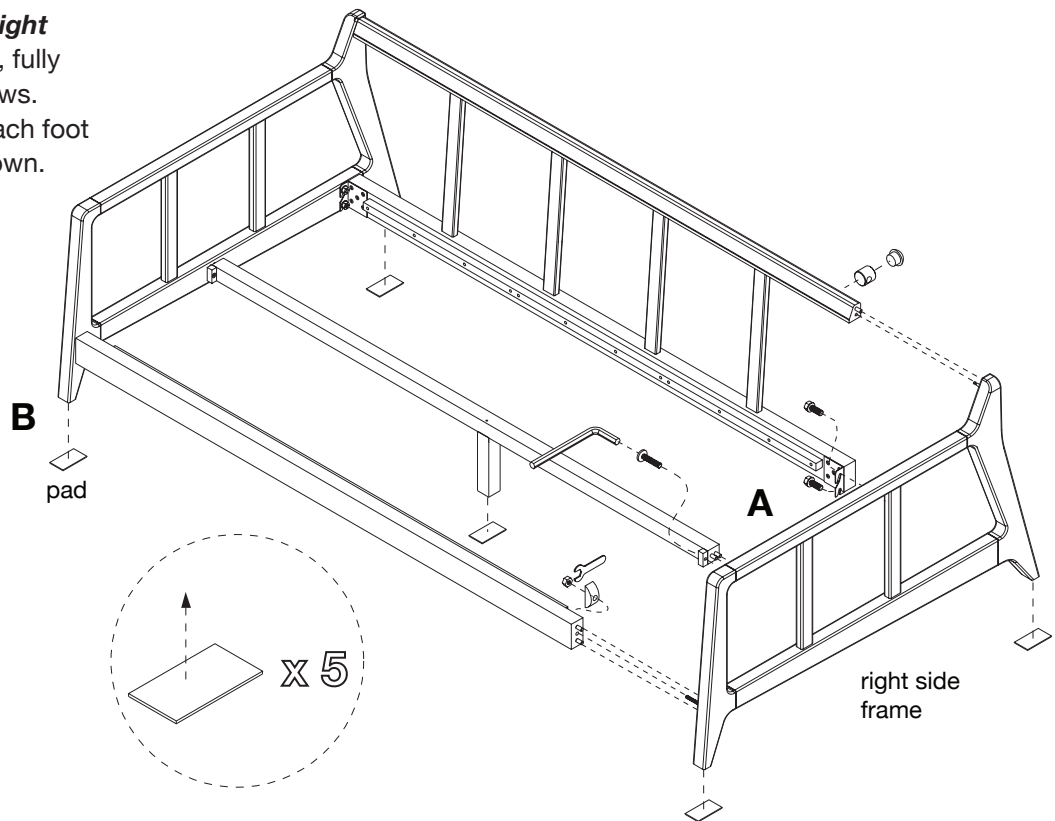

**5**

NOTE: Make sure straps are facing down as shown.

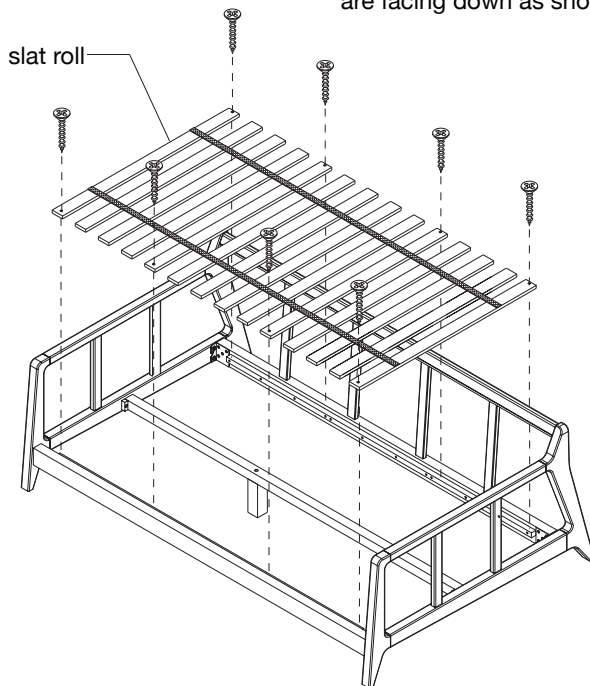

Lay **slat roll** onto assembled unit with fabric straps facing down. Secure with 8 **screws** using a screwdriver as shown.

**6**

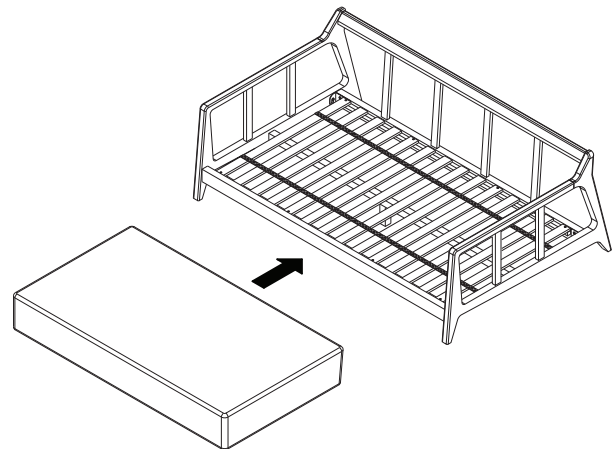

**7** Place **mattress** onto assembled unit. Assembly is now complete.

## CLEANING AND CARE

Clean surfaces with a dry or damp cloth. Do not use abrasive cleaners. Do not use furniture wax or polish as the unit is finished with a protective clear lacquer. Wipe up spots and spilled immediately. Please keep Finn Lounger out of direct sunlight to prevent the mattress cover from fading.