

Thank you for purchasing the **Andes Bed**. This page lists all the contents included in the box. Please take the time to identify the hardware as well as the individual components to this product. As you unpack and prepare for assembly, place the contents on a carpeted or padded area to protect them from damage.

Note: 2 people are required to safely assemble this product.

hardware

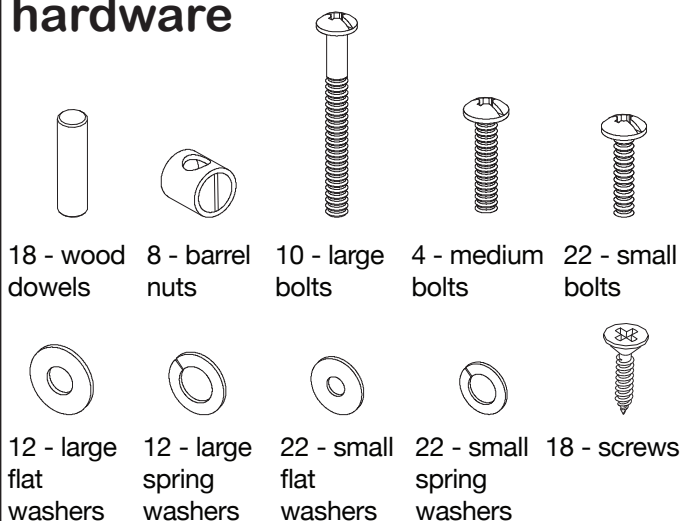

Missing hardware?
Please call **800.606.6387** for replacements.

tools required

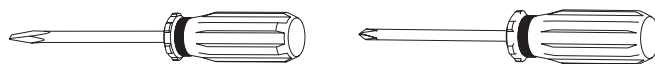

flat head screwdriver phillips head screwdriver
(We recommend the use of hand tools instead of power tools)

components

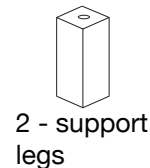
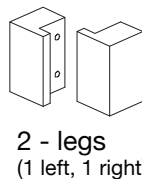
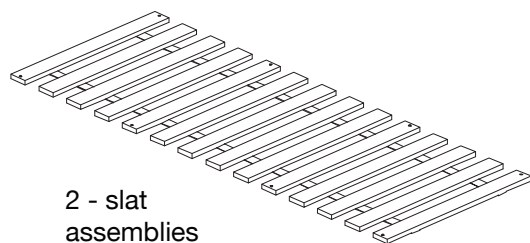
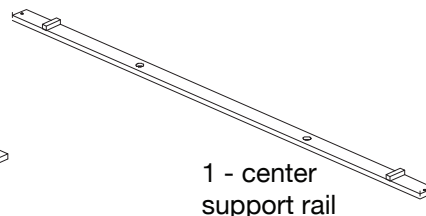
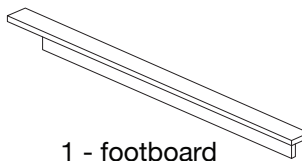
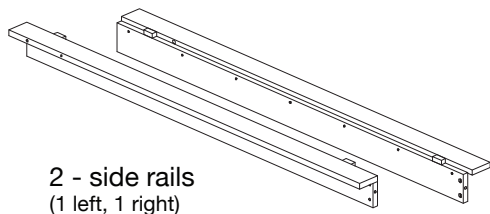
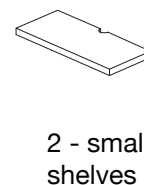
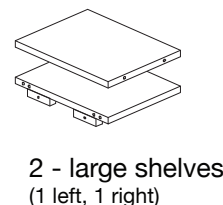
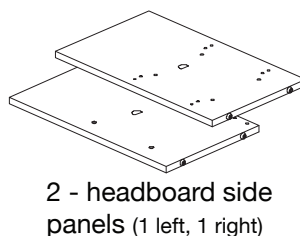
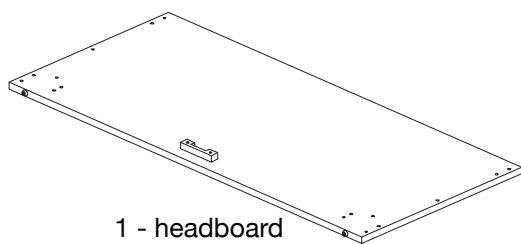

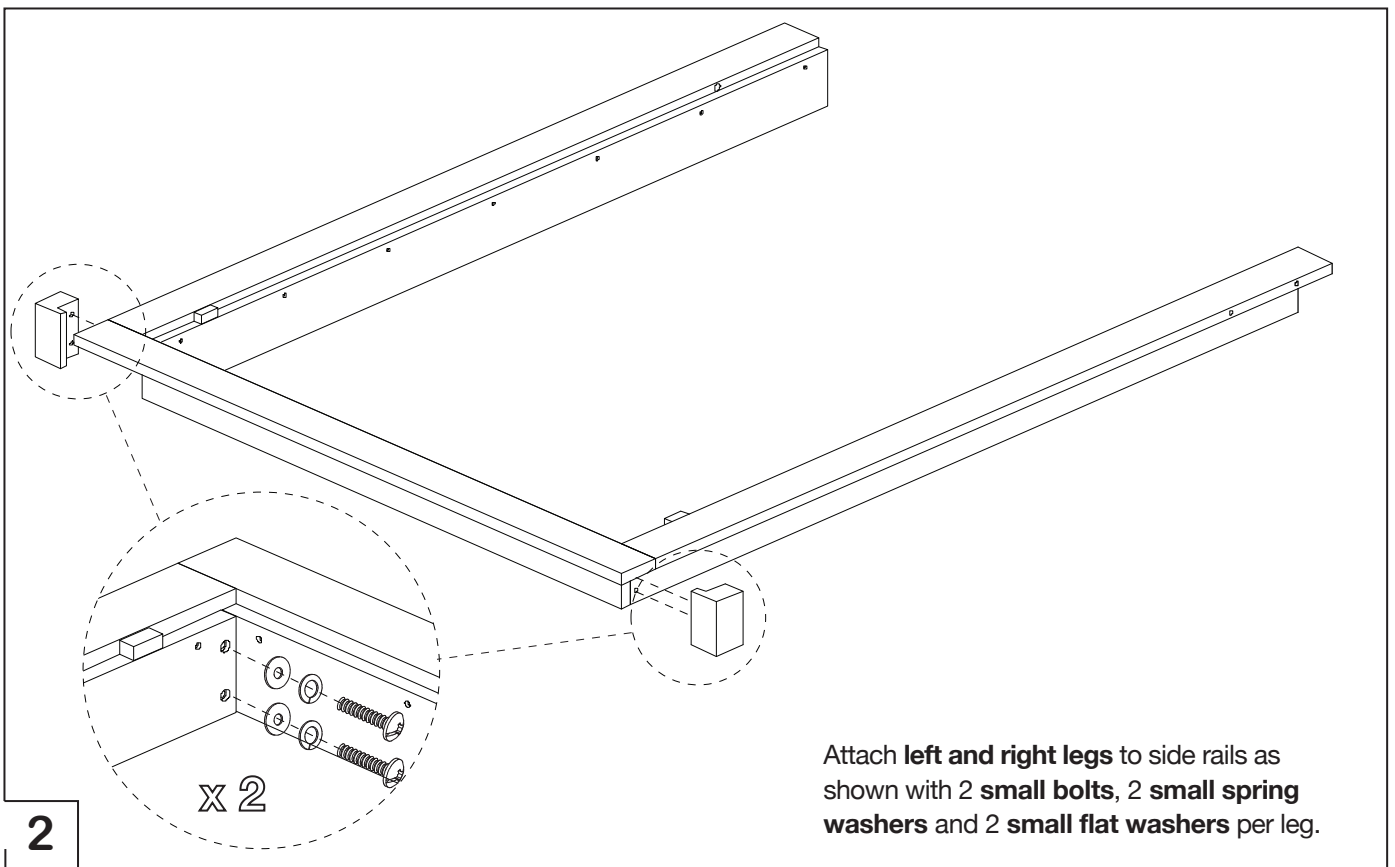
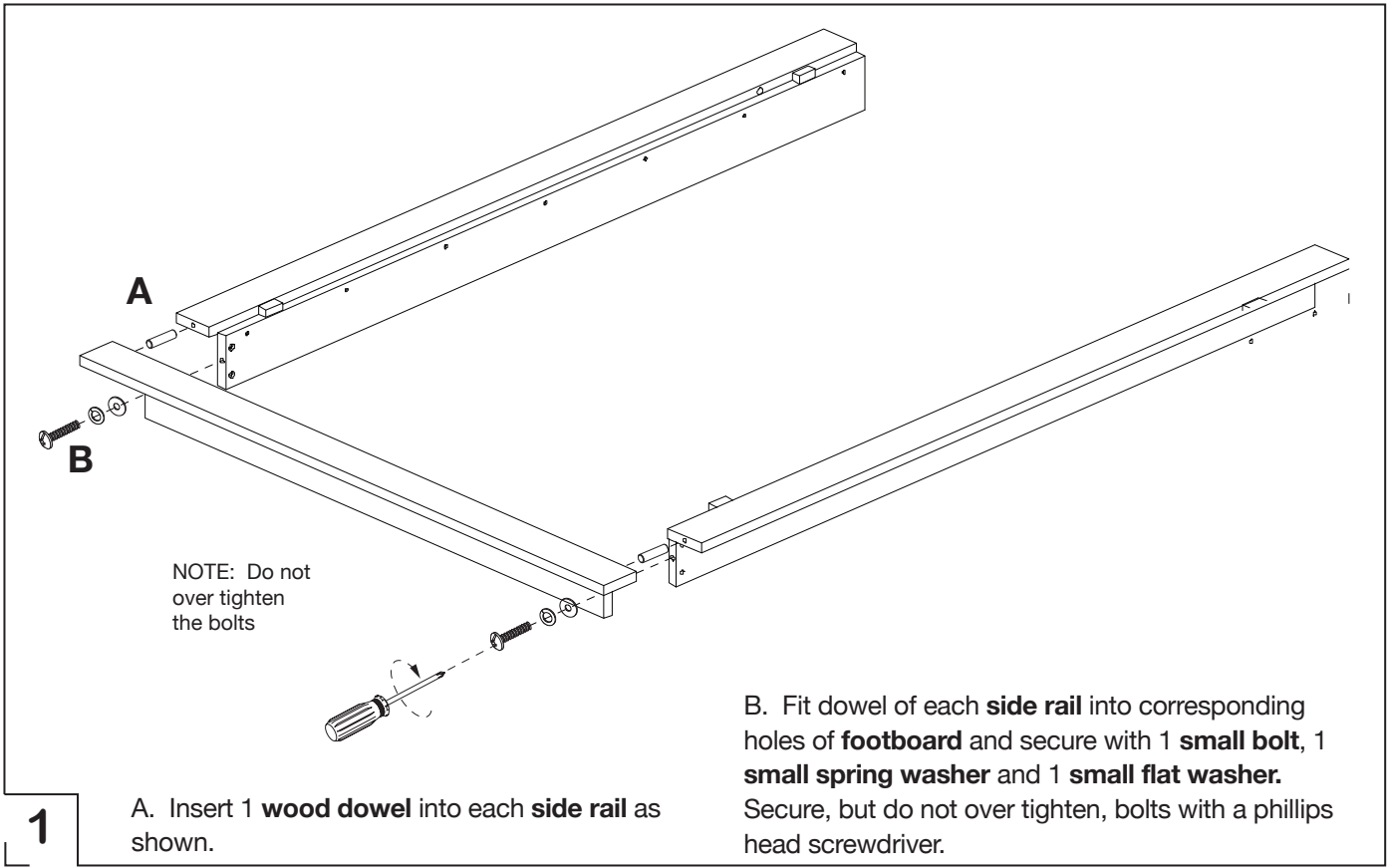

3

A large shelf **X 2**

B small shelf **X 2**

NOTE: Make sure to align hole of each barrel nut with hole on nearest edge

A. Insert 2 **barrel nuts** into each **large shelf** as shown. Using a **flat head screwdriver**, align hole of barrel nut with hole on nearest edge.

B. Insert 2 **barrel nuts** into each **small shelf**.

NOTE: Make sure holes on the edge of the large shelf are on the same side as holes on the back of the headboard side panel

4

A Insert 4 **wood dowels** into **left and right headboard side panels** as shown.

B Fit dowels on **headboard side panels** into **small and large shelves**. Attach each shelf with 2 **small bolts**, 2 **spring washers** and 2 **flat washers** as shown.

Insert 4 **large bolts**, 4 **large spring washers** and 4 **large flat washers** into back of **left and right headboard side panels** and **small/large shelves** as shown. Secure bolts with a **phillips head screwdriver**. Make sure bolts are securely engaged in each barrel nut.

5

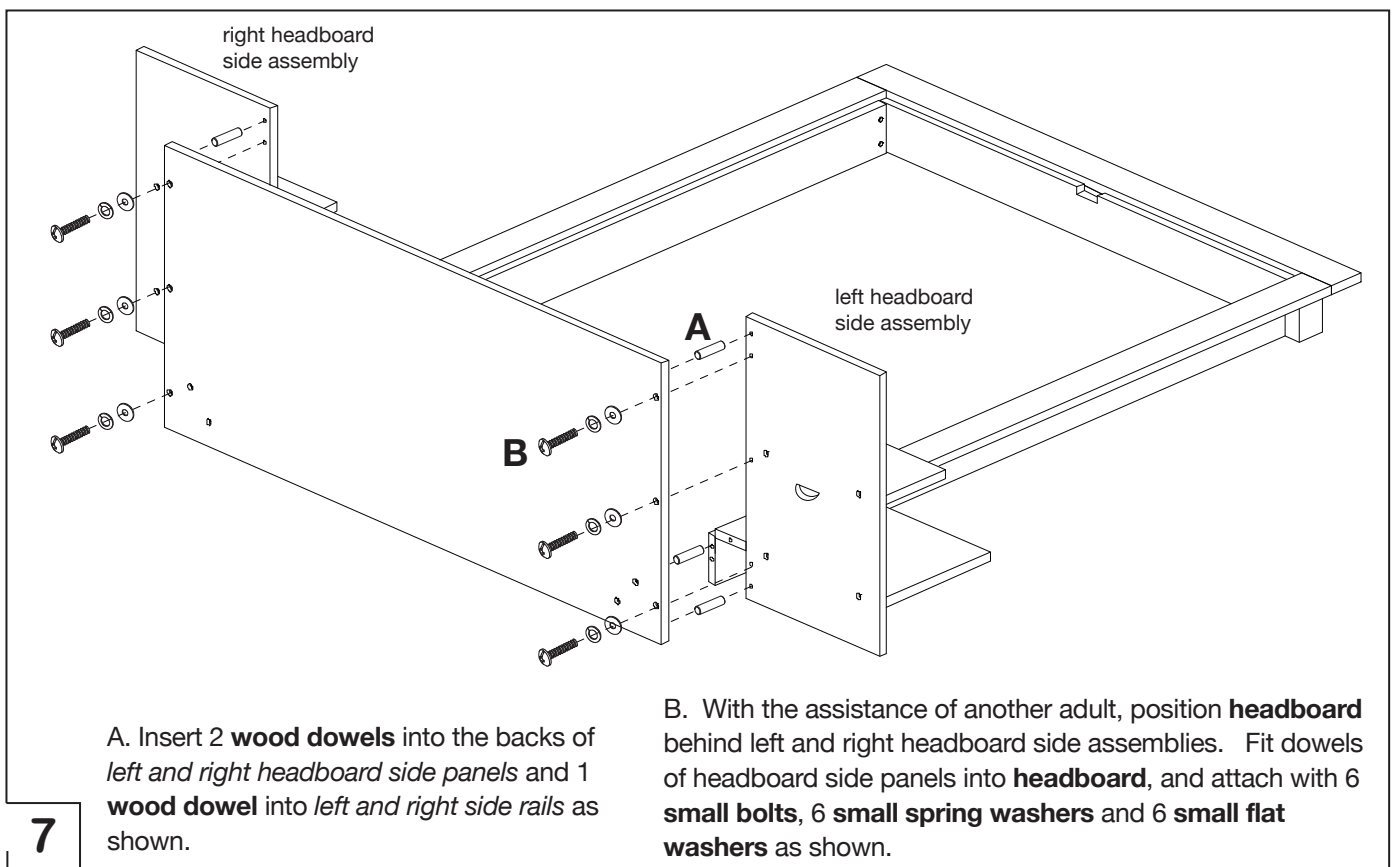
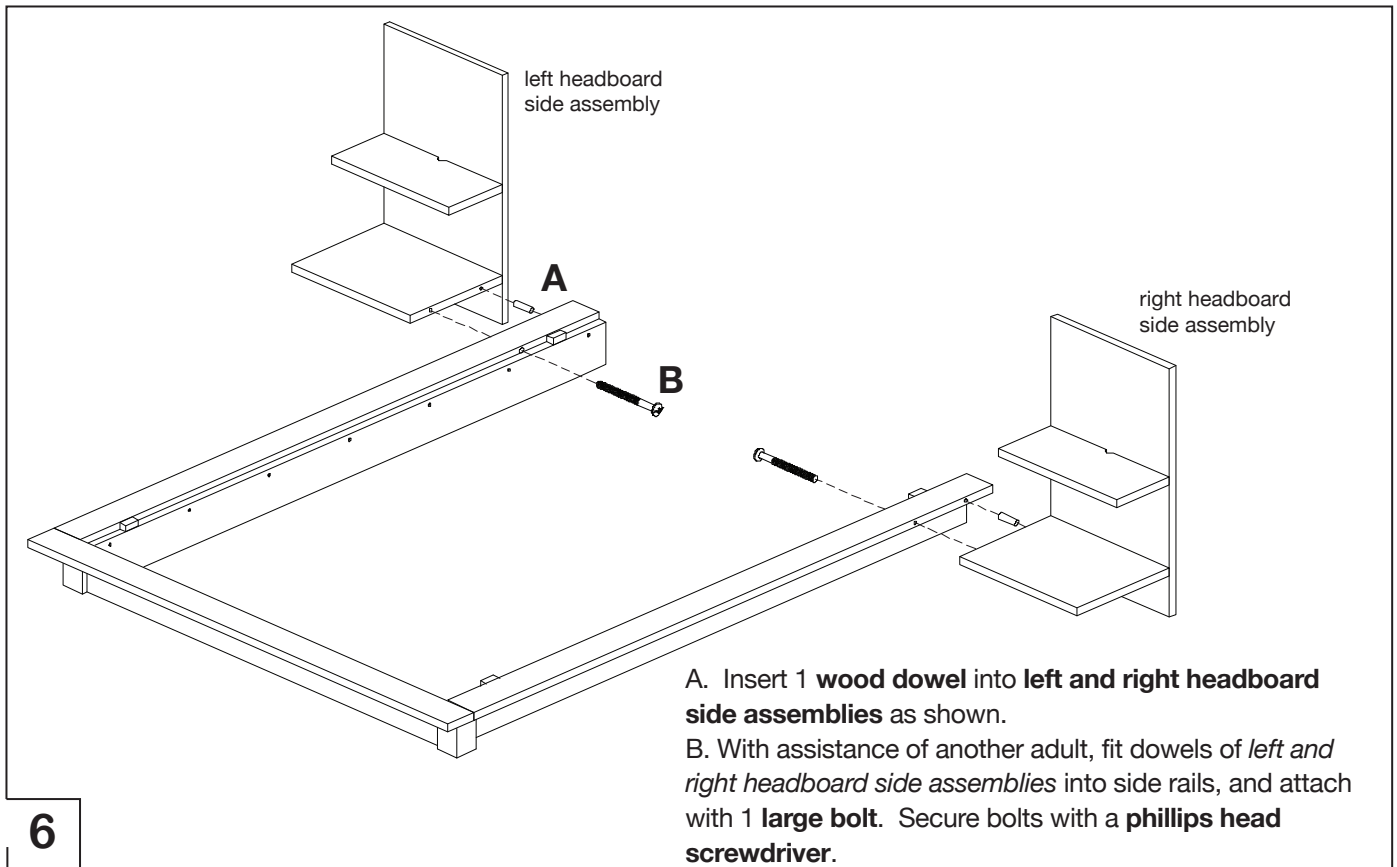

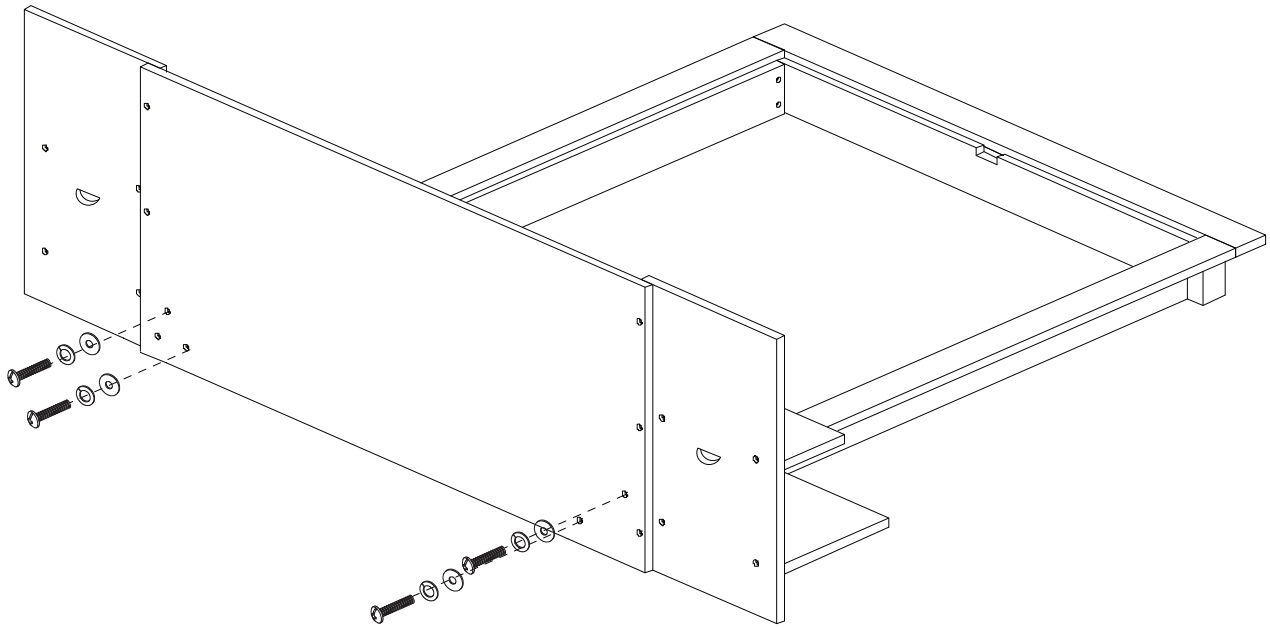

8

Secure headboard to side rails with 4 **medium bolts**, 4 **large spring washers** and 4 **large flat washers** as shown.

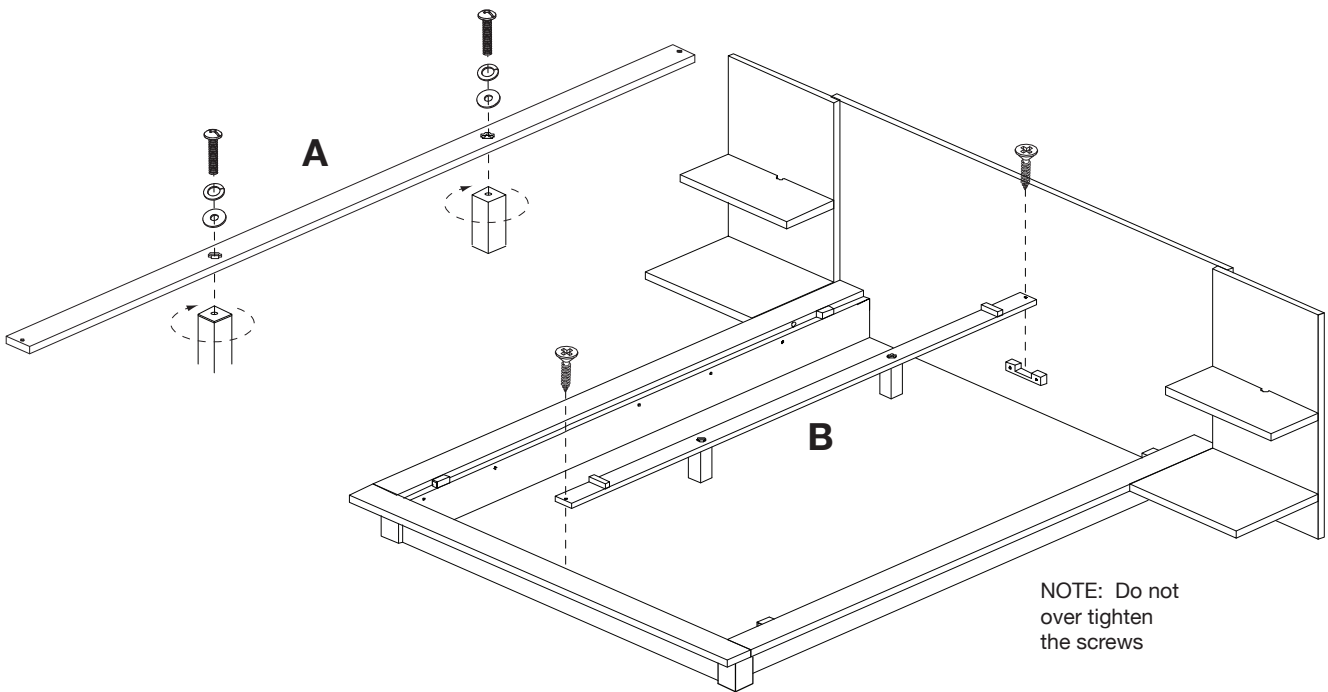

9

A. Attach 2 **support legs** to **center support rail** with 2 **small bolts**, 2 **small spring washers** and 2 **small flat washers** as shown.

B. Attach **center support rail** to brackets of headboard and footboard with 2 **screws**. Secure, but do not over tighten, screws with a phillips head screwdriver.

NOTE: Do not over tighten the screws

Lay each **slat assembly** onto side/center rails as shown. Make sure straps are facing down. Attach each slat assembly with 8 **screws**. Assembly is now complete.

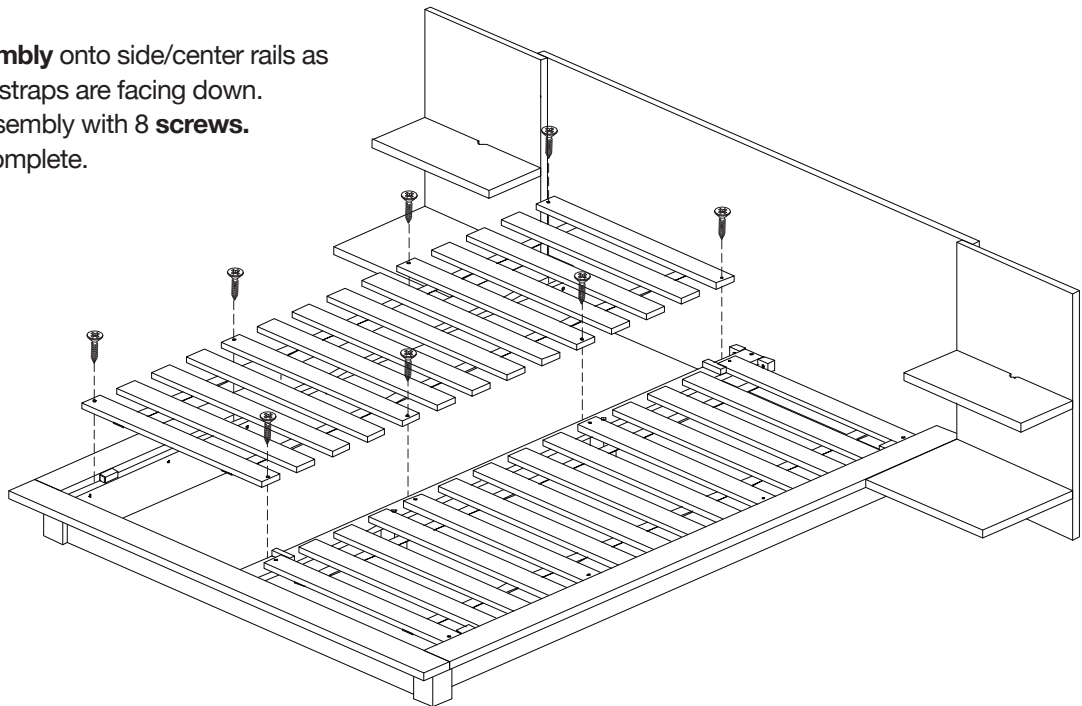

10

cleaning & care

Clean surfaces with a dry or damp soft cloth. Do not use abrasive cleaners. Do not use furniture wax or polish as the unit is finished with a protective clear lacquer. It is recommended to use coasters to protect surface from heat and water.