

Thank you for purchasing the **Alpine Bed**. This page lists all the contents included in the box. Please take the time to identify the hardware as well as the individual components to this product. As you unpack and prepare for assembly, place the contents on a carpeted or padded area to protect them from damage.

Note: 2 people are required to safely assemble this product.

hardware

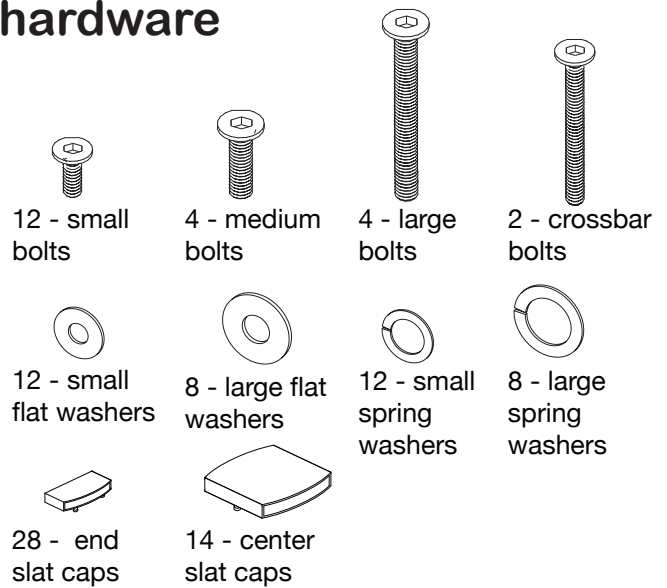

Missing hardware?
Please call **800.606.6387** for replacements.

tools required



small allen wrench and large allen wrench (included)

components

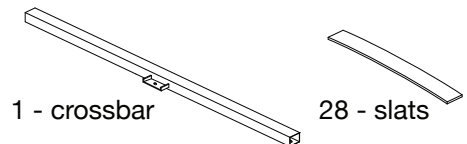
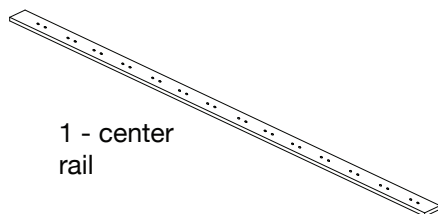
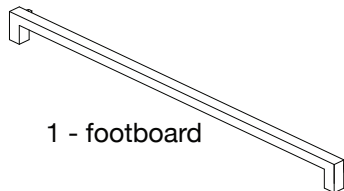
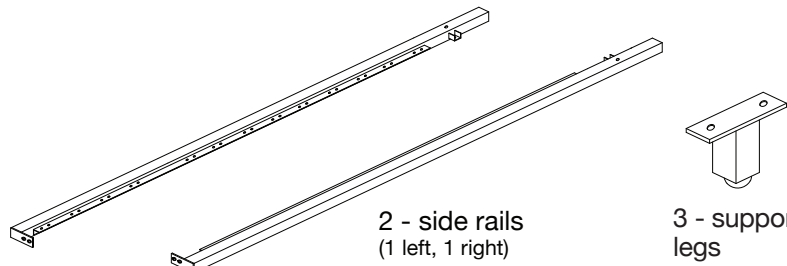
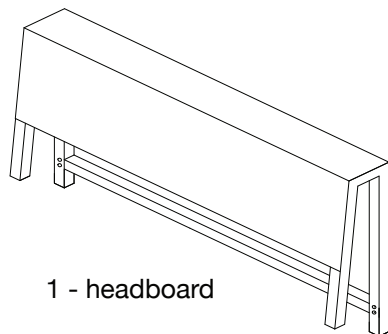

1

Fit **crossbar** into corresponding brackets of **left and right** side rails as shown. Secure each side rail with 2 **small bolts**, 2 **small spring washers** and 2 **small flat washers**, using a **small allen wrench**. Do not over tighten the bolts.

NOTE: Do not over tighten the bolts

2

A) With the assistance of another adult, position assembly as shown. Attach side rails to **footboard** with 4 **medium bolts**, 4 **large flat washers** and 4 **large spring washers**, using a **large allen wrench**. Do not over tighten the bolts.

B) Secure footboard with 1 **small bolt** per side rail, using a small allen wrench.

3

A) With the assistance of another adult, loosely attach **headboard** to **side rails** of assembly with 4 **large bolts**, 4 **large spring washers** and 4 **large flat washers**, using a large allen wrench.

B) Secure each side rail with 1 **crossbar bolt**, 1 **small spring washer** and 1 **small flat washer**, using a small allen wrench. At this point, fully tighten large bolts with a large allen wrench.

4

Attach 3 **support legs** to **center rail** with 2 **small bolts**, 2 **small spring washers** and 2 **flat washers** per support leg. Secure bolts with a small allen wrench.

5 Attach **center rail** to assembled unit as shown with **2 small bolts**, **2 small spring washers** and **2 small flat washers**, using a small allen wrench.

6 Insert **14 center slat caps** into center rail of assembled unit as shown.

7 Fit each **slat** into **end slat cap** as shown.

8 **A.** Fit each slat assembly into corresponding hole of **center slat cap**. Assemble the slat assemblies starting from the headboard to the footboard.
B. Insert each **end slat cap** of slat assembly into side rails of assembled unit.
 Assembly is now complete.

CLEANING AND CARE

Clean surfaces with a dry or damp soft cloth. Do not use abrasive cleaners.